

colorium



saloni.com.tr
2021-1

saloni
art of furniture



Seyfettin PORTAKAL

18.02.1930 - 20.02.2017

21st
year of quality
design.
With Love

saloni

art of furniture



saloni

21 years with pride

Our Esteemed Customers and Valuable Business Partners,

We are happy to say hello to you with our catalog containing our new product collection. This year is a special year for us. We celebrate the 20th anniversary of our partnership together.

I would like to present our new investments and developments related to our company while sharing our very exciting new products which are special in honor of our 20th year. First of all, we have made great strides in our goal of producing robust, aesthetic, and comfortable products that meet the expected quality level all over the world. By increasing our material and workmanship quality, even more, we are progressing with full speed to reach excellence in the way of maximizing customer satisfaction.

We have a strong franchising organization with over 70 branches in Turkey and 40 in all over the world. Especially with our breakthrough in the field of exports, we are exporting 70% of our products to the whole world, mostly Europe.

We crowned this breakthrough in quality and sales by strengthening our production infrastructure. Our new investments; bedrooms, dining rooms, and bedsteads were put into operation at full capacity. Together with our metal factory and sofa production factory, we are in an effort to offer you the best products with a total of 400 employees in 5 factories. Along with our bedroom models, in order to offer you the best options for bedding, we have established strategic cooperation with the Altın Yatak bedding company, which has a deep-rooted history and strong production infrastructure. You will be able to easily access Altın Yatak bedding products from our stores. Since 2000 when we founded Saloni; We are proud to work with our full power to serve you with our stronger production infrastructure, without sacrificing our values, to maintain a moral and trust-based trade with our customers, to produce quality and functional products, to provide a peaceful and pleasant working environment for their employees.

Best regards,

Haluk OZBEK
Saloni Furniture - CEO

Saloni Europe

Our Esteemed Customers and Valuable business partners;

In this period when we celebrate the 20th anniversary of our beginning, we are happy to present our new collection catalog. It also excites us to aspire to our valued customers, who are at the center of the source of this happiness.

As Saloni, we accepted it as the basic value to offer our consumers the most robust, comfortable, and aesthetic products, and to continue to this end, from the very first day we aim for the best. We wholeheartedly thank all of our colleagues and followers who dreamed, designed, exerted, and produced in our new collection, which we presented to you in line with this goal and purpose.

We aimed to make our products much more optional and useful in this collection, where we work with the responsibility given to us by our "being consumer-friendly" value, which is one of the basic values of Saloni. We tried to present to you the imagined living spaces with the right colors, styles, and designs. Of course, there is no limit to dreams, as our dreams have no limits, we have infinite energy to do better, design, and produce better.

We continue to work on new projects in order to make Saloni a more preferred and faster brand in every field with the awareness that the success equivalent to labor cannot be achieved only with a good collection.

In this context, we create a sales and storage center in Germany in order to achieve higher success in European countries, to better identify European furniture habits. Our sales and storage center, which we started six months ago and will start operating at the end of 2020, will be able to deliver to all of Europe within 24 to 72 hours. In addition to this, we will be able to present a significant

part of our products in our collection to our liking in a corporate store environment with the exemplary corporate stores we have created in Germany.

We know that in order to create livable houses, it is necessary to analyze the consumer's expectations well. Presenting every correct analysis and product with the right concept is the main success criterion for furniture sales. Because we see the products that are the subject of the dream and offered to the taste of the consumers as a work created by the furniture artist with effort. In addition to the beauty of the work, we find it very important that it is designed with so much care in the space that covers it.

With the Saloni European structuring; In addition to providing products to its dealers faster, it will show that Saloni is closer to its dealers than before, and will continue to offer the best service to its dealers by taking inspiration from Europe's design power and innovation success.

Best regards,

Ismail OZBEK
General Manager
Saloni EU



A work of mathematics!

The world of imagination has no boundaries. What matters in the furniture sector is the applicability of the imagined lines. Customer experiences, production, and the resulting designs... Are like pieces of an incomparable jigsaw puzzle. And the pieces should be able to solve an equation.

Dear Customers and Business Partners,

We are celebrating our 20th year this year. We are very happy and proud to share our new 20th year collection with you. First of all, we would like to thank you for being with us on this journey on behalf of the entire Saloni family. In the coming years, our aim to produce robust, aesthetic, functional and comfortable products will continue without stopping.

In this period, which is one of the most important milestones in the history of Saloni, we have reached a stronger production infrastructure. Our new investments, bedroom plant, dining room plant and bedstead plant have started production with full capacity. In addition to infrastructure investments, as a result of the importance we attach to quality and human resources, we have launched many new projects.

In order to ensure the continuous improvement of the Saloni teams, to follow these developments systematically and to transfer the necessary information quickly and effectively, we established Saloni Academy. In addition to formal trainings such as on-the-job practical trainings and classroom trainings, we have also developed an online training platform that will enable distance learning regardless of time and place. In this way, it is possible for all our team members working at our factories and in stores and sales points all over the world to reach the necessary trainings easily and quickly.

The durability and safety of our products, which have

been appreciated by our customers for years, have also been certified with an international certificate. We have been entitled to receive EN 12520 certificate after our production system and products were audited. The EN 12520 European Standard is a standard that covers the requirements for the strength, durability and safety of seating elements used by adults in homes. With this certificate, we have passed an important stage in terms of quality and durability. In the coming period, we will continue to work on improving our system and products with other relevant certificates.

I would like to specially thank our employees who have the biggest share in Saloni's success. Each of our products has a great effort and care of our 400 employees. We see our human resources as our most important wealth and work harder for their development and happiness.

Ahmet OZBEK

Saloni Furniture
General Manager - Saloni Turkey



Saloni International Quality Certification Program

Saloni brand products have been certified based on EN 12520 European Standard that was prepared by European Technical Committee on Standardization (CEN)

Our products were tested based on:

- Production system
- Product strength and durability
- Product and material safety
- Long lasting and sturdiness

criteria and successfully fulfilled the necessary conditions and CEN/EN 12520 certified.

Certified Quality...



We have always kept our sensitivity for quality and durability at the top level in Saloni products for 20 years. The first thing that comes to mind when it comes to Saloni has always been durability, security and ergonomics. It is indispensable for us to offer aesthetics and comfort to our customers with these features.

The durability and safety of our products have been certified with an international certificate. We have been entitled to receive EN 12520 certificate after our production system and products were audited.

EN 12520 European Standard is a standard covering the requirements for the strength, durability and safety of seating elements used by adults in homes. This standard has been prepared by the European Technical Committee on Standardization (CEN) Furniture Technical Committee, and has been

approved by CEN and entered into force. This standard covers the points related to the safety of the user in the seats, armchairs and other seating elements used at home and the specifications to guarantee the durability of the product. In order to obtain this document, our production site inspection and a quality management system inspection carried out primarily. After this preliminary examination is passed, the sample products are subjected to the tests specified in the standard. Products that provide strength, durability and safety conditions passed the tests successfully and are entitled to receive this certificate.

We have passed an important milestone in our quality journey by registering our system with first with our ISO 9001 Quality Management System Certificate and finally with our EN 12520 Certificate. This is not a destination, because we believe that quality is a journey, not a destination...





60 COUNTRIES 230 SALES POINT

ALGERIA	ALGER ORAN MOSTAGANEM BLIDA	FRANCE	RENNES	ITALY	COMO	OMAN	MUSKAT
AUSTRIA	VIENNA	GAMBIA	BANJUL	IVORY	ABIDJAN	PALESTINE	RAMALLAH NABLUS
AZERBAIJAN	BAKU	GERMANY	BERLIN BIELEFELD KÖLN COLOGNE WUPPERTAL DUISBURG AACHEN FRANKFURT STUTTGART WIESBADEN HANAU	JORDAN	AMMAN	PAKISTAN	KARACHI
B.A.E	DUBAI			KAZAKHISTAN	ALMATY NURSULTAN	POLAND	WARSAWA RADOMH
BAHRAIN	ABU DHABI MANAMA			KENYA	NAIROBI KAMPALA	ROMANIA	BUCURESTI
BELGIUM	ANTWERP BRUSSELS CHARLEROI GENT			KYRGYZSTAN	BISHKEK	RUSSIA	MOSCOW ST PETERSBURG
BOSNIA H.	BANJA LUKA			KOSOVO	GILAN PRISTINA FERIZAJ	SAUDI ARABIA	RIYADH MEDINA
BULGARIA	VARNA SOFIA PLOVDIV HASKOVO VELIKO TIRNOVA BURGAZ			KUWAIT	KUWAIT	SERBIA	BELGRADE
COLOMBIA	MEDELLIN BARANQUELLA			LEBANON	BEIRUT	SUDAN	KHARTOUM
CROATIA	ZAGREB			LIBYA	TRIPOLI BENGHAZI	SWITZERLAND	ZÜRICH ROTHRIST
CYPRUS	SPLIT GIRNE			LITHUANIAN	VILNIUS	SIERRA LEONE	FRETOWN
DOMINICAN	SANTA DOMINGO			MALTA		SRI LANKA	COLOMBO
DJIBOUTI	DJIBOUTI			EGYPT	CAIRO	TANZANIA	DAR ES SALAM
EGYPT	CAIRO			MONGOLIA	ULANBATAAR	TUNISIA	TUNUSIA SFAX
				MOLDOVA	CHISHINEV	TURKMENISTAN	ASHGABAT
				IRAN	TEHRAN TABRIZ	UGANDA	KAMPALA
				IRAQ	BAGHDAD ERBİL	UKRAINE	ODESA
				ISRAEL	HAIFA YARFA DARI DELIAT EL CARMEL	UK	LONDRA
						UZBEKISTAN	TASHKENT
						USA	NEW JERSEY
						QATAR	DOHA

The initial cycle: THE ADVENTURE OF FURNITURE

Saloni carries the inspiring elements of nature by embracing them in its new products. Cooking them in the kitchen of the business, the brand turns the musical notes of the desired pleasures into realism through its products and displays them in their bares and bones.

Rapidly adapting to the dynamics of the always-evolving sector is only possible by working hard, and monitoring and internalizing the developments. Saloni

blends together the knowledge of the past and the foresight of the future while keeping close to its inspiration, nature, and stays dynamic. Never content with, the company always produces to achieve more.

Chasing modernity, containing minimalism, reducing the complexity to simplicity, the company is already working hard to create the utopian future through its products.

An orchestra where artists who know the notes and specialize in different instruments come together.

Here we can see Abdullah CANSEVEN. Beginning his carrier at the age of 23 in Saloni Furniture following his education in Industrial Product Design, he acts as the team leader for the design, internal architecture, and R&D departments. While contributing creative touches to the new collections, CANSEVEN and his team always reach for the undiscovered.

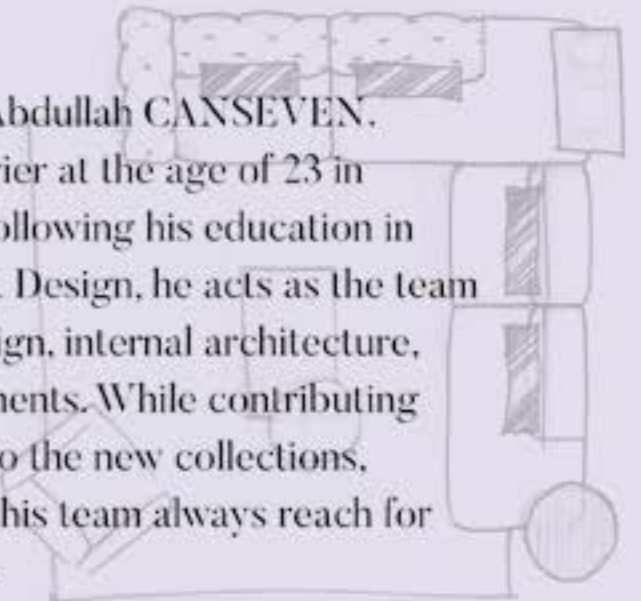

Second cycle: THE PATH THAT LEADS TO EUROPE

This is actually a journey of style, from the Italian-inspired designs that form the value chain of the sector to the flaunting French recherche. With a team of Turkish designers and many years of experience under the belt, Saloni raises to face the style cycle of the West. Yet, the company threads this path carefully when synthesizing the West and the East, so it actually introduces an authentic style to the western modernity. The elements of value that emerge from this path carry a novel sensation into the elated, peaceful houses. And this is where the story actually begins. From the end towards the beginning, Saloni carries the modern lines with them like a delicate nuance.

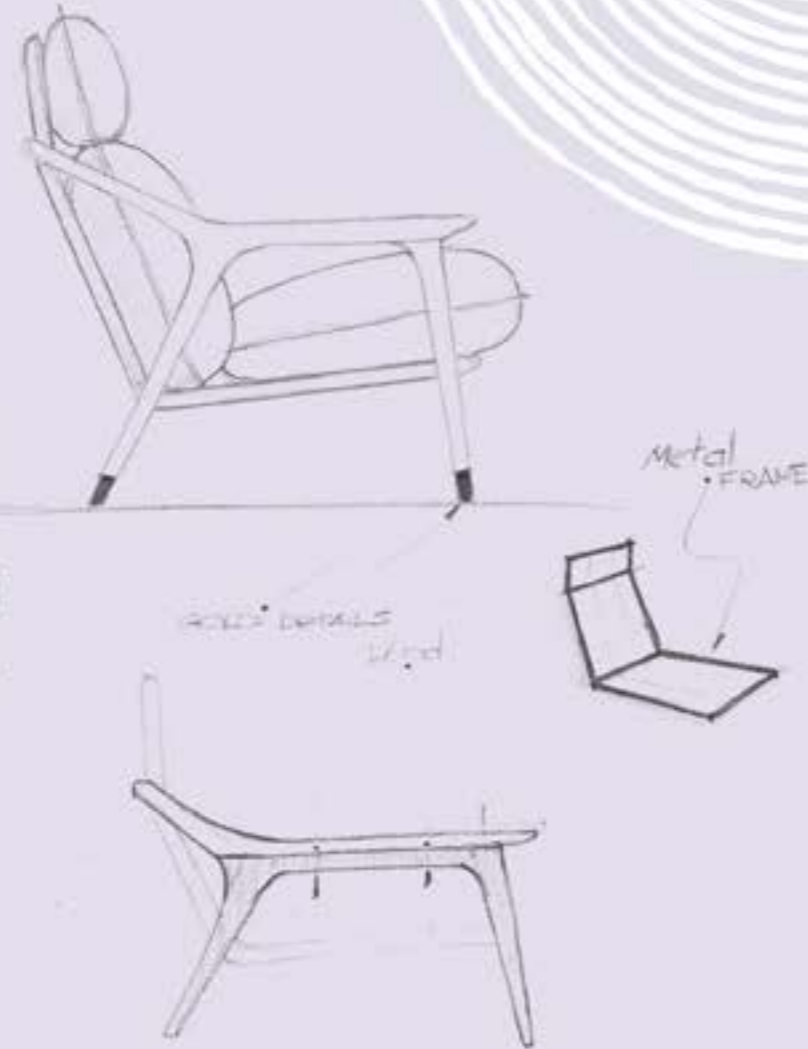

**Abdullah
CANSEVEN**
Saloni Furniture
Lead Designer

I'm talking about an orchestra of artists that know the "musical notes", yet each specializing in a different instrument. Yes, I believe this is one of my greatest mottoes: we aim to introduce new instruments to our team every day. In order to be able to create artworks that can be considered worldwide classics, we tirelessly work and enjoy the feast at the same time.

For me, to be able to design is the capability to discover what already exists, so a designer should also be a good explorer. One should look at this with a philosopher's perspective, and in fact become a philosopher, and should reach the point where one can present his/her own philosophy. We have witnessed during the history, and in fact, still witnessing, how the designers that see each of their pieces as steps to prove their own philosophy have produced authentic results.

The two elements that I care most in a design: "Balance and Harmony". Not only have numerous sub-contexts existed under this balance, but also more sub-contexts under these as well. Without an alternative, the place where balance and harmony present itself is the "Nature". As Fernando Caruncho states: "the human mind, stronger than many other powers, is the most advanced computer". We have to connect with nature, which is far stronger than humans, and we have

to nourish our minds with it. When the human mind is experiencing nature, all 5 senses are active. When we observe it, feel it, and try to recognize its power, we are able to understand more than any other technology can provide. The technology, which can never reach the power of nature, can only be an instrument in understanding it. When you trust all your mind and senses to a greater power, an artwork emerges.

Amongst the designers who I believe had analyzed these two important elements, Jean Marie Massaud and Maurizio Manzoni are in the lead for me.

We can see that particular sets of skills are valued more in various places in the world. In Italy, it's the design, while in Germany, it's the engineering. In Greece, it's philosophy, while in Japan, it's efficiency, and in Korea, it's technology. The world is large, and there are people who do their job justly. A designer should embrace these skill sets and should make use of all the resources available to him/her. A designer should hold the world in his/her palm, and fight to realize the dreams in an incredibly free and authentic manner. A designer should also preemptively accept that the truth of yesterday might not be the truth of today, and future. Not content with this information, a designer should also aspire to create the truth of tomorrow.

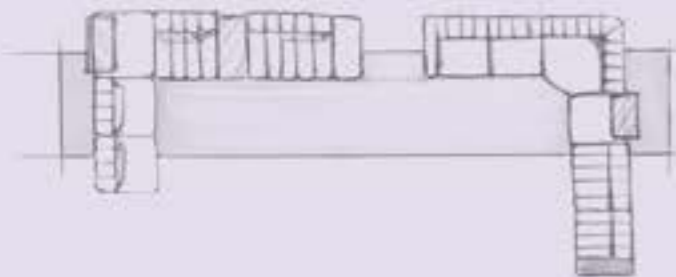

SALONI DESIGN TEAM



abdullah canseven
lead designer



ayse toprak
interior designer



dastan abishev
industrial designer



ayse bahadir
graphic designer



mehmet akif uz
interior designer



abdullah sen
graphic designer



menguha ordu
styling



ozge pisiren turkoglu
product design

WHY INEGOL?

Inegol is the largest furniture production center in the Eastern Europe with its global potential.

History of furniture production tradition in Inegöl dated 1874. With its location in the Western part of Turkey Inegöl has access to sea ports (45 minutes) and airports (15-120 minutes).

Briefly, Inegöl city is the center of furniture which has high capacity and global standards.



City of Inegol with Numbers



- Annual furniture production and sales in Inegöl reaches 4 billion dollars.
- Exporting over 150 countries around the World.
- The number of factories with at least 50 personal and over is 2100.
- These factories have 5 million square meters covered space.
- Inegöl city has 3 organized industrial zones for furniture production and 1 organized industrial zone for mix industrial production.

- The number of people who employed for specifically furniture production is 108.000.
- Inegöl city has 3 shopping street and 2 big scale shopping centers which are consist of the stores of production companies and open 365 days.
- These shopping centers and shopping streets have over 571 stores.



content

| 20 |

RENAISSANCE
SERIES

| 62 |

BOHEMIAN
SERIES

| 84 |

GIPSY
SERIES

| 102 |

COLORIUM
SERIES

| 44 |

AMAZON
SERIES

| 74 |

WILD
SERIES

| 94 |

NON FIGURATIVE
SERIES



ASPENDOS

I T A L I A N

ASPENDOS

Original interpretation of an extraordinary production.

PAGE - 21
ASPENDOS

H E L E N

PAGE - 20



RENAISSANCE, SALONI



MICHELANGELO
BEDSTEAD

CHELSEA
SMALL POUF
(QUILTED)



MICHELANGELO
BEDSTEAD

The Power of Patterns

A style that combines different patterns and carving art.



EFES
MURILLO



EFES MOTHER
ARMCHAIR



EFES NAPOLYON
ARMCHAIR



Time to Make a Difference

Designed and dedicated to a "warm and cozy environment" associated with implications of "home" in modern architecture. Poufy is a masterpiece created for comfortable spaces. It demonstrates an understanding of architecture that goes beyond with its austere look evoking a sense of comfort, solidity and functionality.



**POUFY
HELEN**

Sustainability

It was designed for those who chase after "the new" at all times.



Energetic and graceful

Featuring timeless details, California bears the creative signature of the designer in every single detail.

CALIFORNIA
CERRADO





PAGE - 33
CALIFORNIA

Discover Different Styles

Displaying an integrated harmony between sharp curves of armrest and soft lines of backrest, California delivers aesthetical heritage to indoor spaces.

CALIFORNIA
TIGER



PAGE - 32

RENAISSANCE, SALONI



HAVANA



FRIDA
DORIA
POUF

Time to display abundance indoors!

Eye-catching design, ergonomic form and functional composition of Havana creates a luxurious ambience without an effort.



FRIDA
HAVANA



ASPENDOS
ITALIAN



Look at beauty

PAGE - 38

RENAISSANCE, SALONI

**POUFFY
COSMOS**

**ASPENDOS
HELEN**

**CHELSEA
SMALL POUF
(QUILTED)**

**CHELSEA
BIG POUF**



POUFY

C O S M O S POUFY

Designed and dedicated to a "warm and cozy environment" associated with implications of "home" in modern architecture. Poufy is a masterpiece created for comfortable spaces. It demonstrates an understanding of architecture that goes beyond with its austere look evoking a sense of comfort, solidity and functionality.



EFES
MURILLO

BAGDAT
MIDDLE
COFFEE TABLE

PAGE - 41
ASPENDOS

ASPENDOS
HELEN



Sustainability



POUFY
COSMOS

Technical Details

ASPENDOS

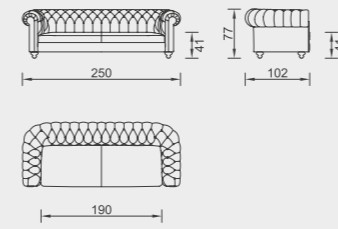

KG: 75,0 m³: 1,86

CALIFORNIA 4 SOFA

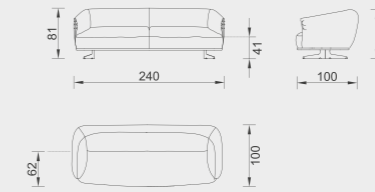

KG: 85,0 m³: 1,78

EFES
ARMCHAIR

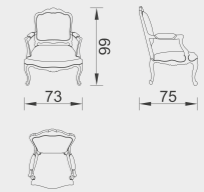

KG: 13,0 m³: 0,59

POUFY

INTER MODULE

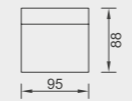

KG: 29,0 m³: 0,67

HIGH ARM MODULE RIGHT



HIGH ARM MODULE LEFT



KG: 45,0 m³: 0,87

LOW ARM MODULE RIGHT

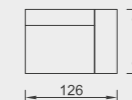

LOW ARM MODULE LEFT

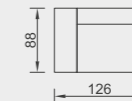

KG: 42,0 m³: 0,98

CORNER MODULE RIGHT

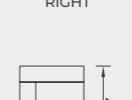

KG: 45,0 m³: 0,87

POUF



KG: 19,0 m³: 0,35

POUFY
HELEN

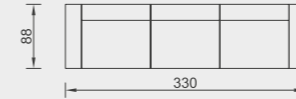

KG: 119,0 m³: 2,41

POUFY
COSMOS 1

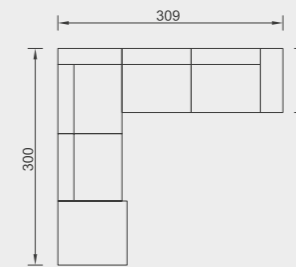

KG: 164,0 m³: 3,54

POUFY
COSMOS 2

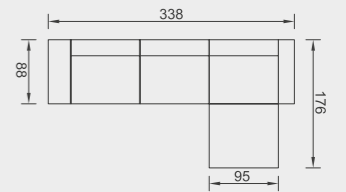

KG: 135,0 m³: 2,87

HAVANA

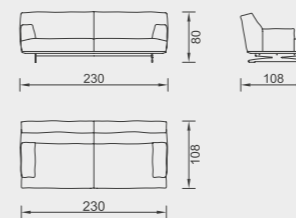

KG: 88,4 m³: 1,74

DORIA PUF

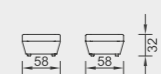

KG: 5,0 m³: 0,13

CHELSEA BIG PUF

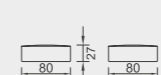

KG: 12,0 m³: 0,25

MICHELANGELO
BEDSTEAD

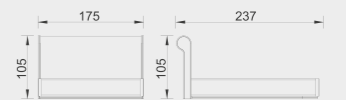

KG: 185,0 m³: 1,27



FOX BIRD,
AMAZON

MONATERA
MIDDLE COFFEE TABLE

FELIX BIRD, AMAZON



Amazon FOX BIRD

Exotic leaves. Although European colonists brought their formal furniture traditions to their new island homes, they adapted them to suit local customs and indigenous resources such as teak, rosewood, and mahogany.



DREAM CATCHER



PAGE - 49
FELIXBIRD

Amazon FELIX BIRD

Thus sprouted an offshoot style of furnishings that blended classic profiles with rich hardwoods and lushly carved embellishment-Continental elegance imbued with the soul of the tropics. Antiques in this style murmur of a colorful past, but reproductions or updated versions make worthy stand-ins.



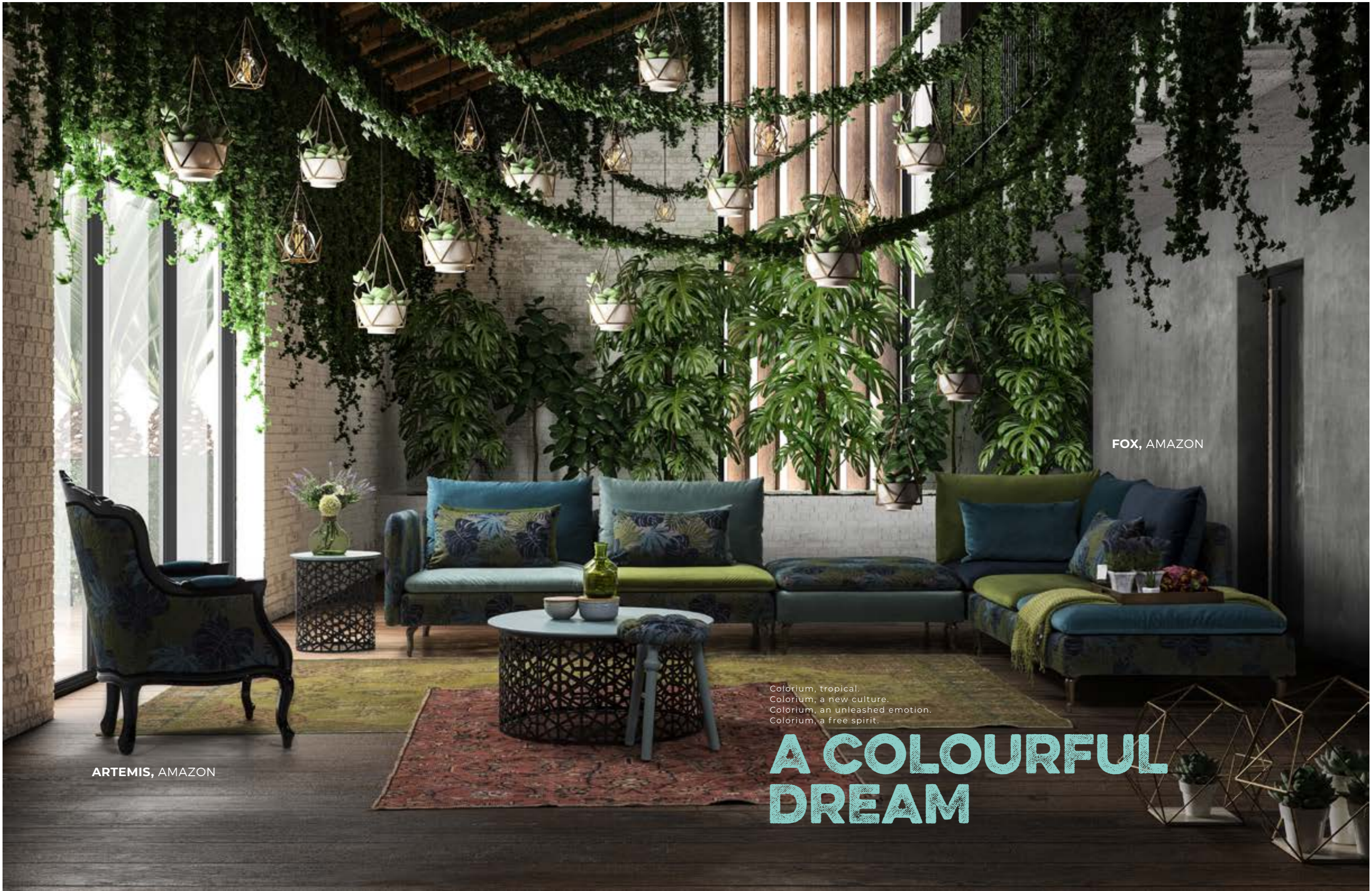

ARTEMIS, AMAZON

FOX, AMAZON

Colorium, tropical.
Colorium, a new culture.
Colorium, an unleashed emotion.
Colorium, a free spirit.

A COLOURFUL DREAM



FOX
Amazon



FELIX, AMAZON

PI
SIDE
TABLE

PI
MIDDLE
COFFEE
TABLE

CALIFORNIA
POUF

MONATERA
SIDE TABLE



Amazon
PICASSO



"LOST WORLD"

DEEP IN THE
AMAZON FOREST



ARTEMIS 1
AMAZON
ARMCHAIR



ARTEMIS 2
AMAZON
ARMCHAIR



POUF 1



FELIX 1
AMAZON
ARMCHAIR



FELIX 2
AMAZON
ARMCHAIR



POUF 2



ARM
MODULE
LEFT



ARM
MODULE
RIGHT



INTER 1
MODULE



CORNER
MODULE
LEFT



CORNER
MODULE
RIGHT



INTER 2
MODULE

EMBRACE COLOURS

Tropical style isn't about hard and fast design rules it's equal parts local custom and state of mind. It springs from the part of the world that sits between the Tropics of Cancer and Capricorn, and because it spans so many different countries and cultures, its nuances are many and diverse. The region's strong seafaring tradition brought settlers from far-flung points of the globe who added their own native traditions to create a multilayered, arresting blend.

PAGE - 57
POUFY TUKAN

Amazon
POUFY
TUKAN





Technical Details

Technical Details

ARM MODULE LEFT

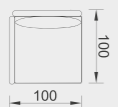

KG: 35,7 m³: 0,61

ARM MODULE RIGHT

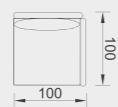

KG: 35,7 m³: 0,61

INTER MODULE



KG: 30,0 m³: 0,51

CORNER MODULE RIGHT

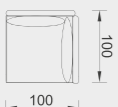

KG: 36,0 m³: 0,63

CORNER MODULE LEFT

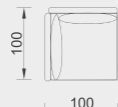

KG: 36,0 m³: 0,63

POUF

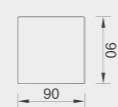

KG: 20,0 m³: 0,22

OPTION 7

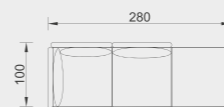

KG: 86,0 m³: 1,36

OPTION 8

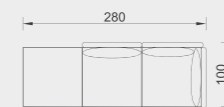

KG: 86,0 m³: 1,36

OPTION 9

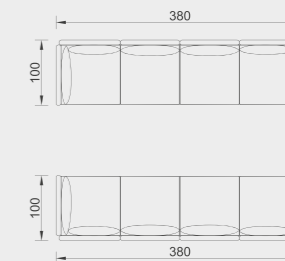

KG: 264,0 m³: 4,56

OPTION 10

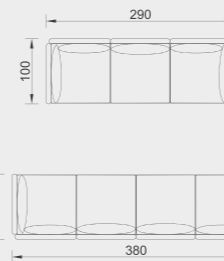

KG: 234,0 m³: 4,05

OPTION 11

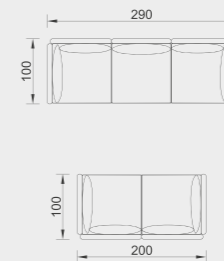

KG: 174,0 m³: 3,03

OPTION 12

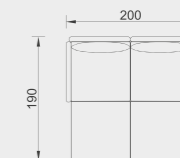

KG: 111,4 m³: 1,66

OPTION 1

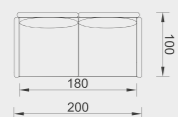

KG: 71,4 m³: 1,22

OPTION 2

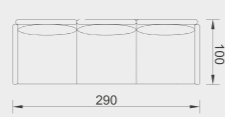

KG: 101,4 m³: 1,73

OPTION 3



KG: 142,8 m³: 2,44

OPTION 13

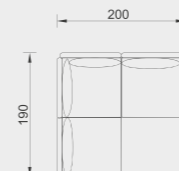

KG: 101,7 m³: 1,75

OPTION 14

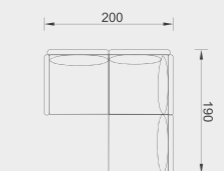

KG: 101,7 m³: 1,75

OPTION 15

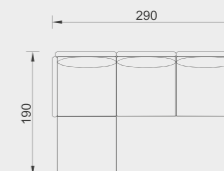

KG: 121,4 m³: 1,95

OPTION 4

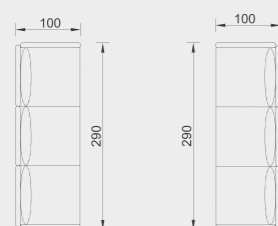

KG: 202,8 m³: 3,46

OPTION 5

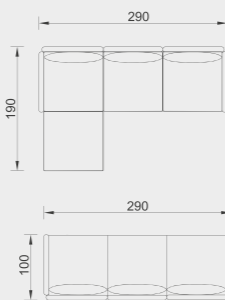

KG: 222,8 m³: 3,68

OPTION 6



KG: 121,4 m³: 1,95

OPTION 16

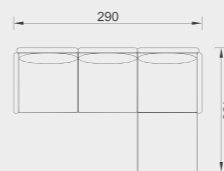

KG: 121,4 m³: 1,95

OPTION 17

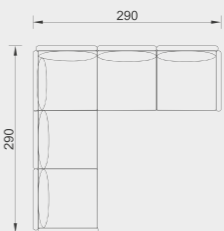

KG: 167,4 m³: 2,87

OPTION 18

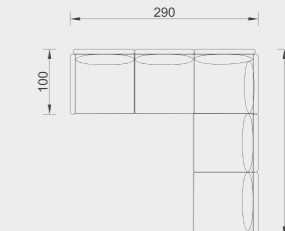

KG: 167,4 m³: 2,87



Technical Details

Technical Details

OPTION 19

KG: 197,4 m³: 3,38

OPTION 20

KG: 227,4 m³: 3,89

OPTION 21

KG: 227,4 m³: 3,89

OPTION 22

KG: 293,4 m³: 5,03

OPTION 23

KG: 201,7 m³: 3,21

OPTION 24

KG: 211,7 m³: 3,50

OPTION 25

KG: 151,4 m³: 2,46

OPTION 26

KG: 137,4 m³: 2,36

OPTION 27

KG: 137,4 m³: 2,36

OPTION 28

KG: 217,4 m³: 3,50

OPTION 29

KG: 217,4 m³: 3,50

OPTION 30

KG: 263,4 m³: 4,52

OPTION 31

KG: 192,0 m³: 3,30

OPTION 32

KG: 162,0 m³: 2,79

OPTION 33

KG: 120,0 m³: 2,04

OPTION 34

KG: 152,0 m³: 2,50

ARTEMIS AMAZON ARMCHAIR

KG: 16,5 m³: 0,61

FELIX AMAZON ARMCHAIR

KG: 15,6 m³: 0,28

FOX BIRD

KG: 101,4 m³: 1,73 **KG: 35,7 m³: 0,61** **KG: 30,0 m³: 0,51** **KG: 35,7 m³: 0,61**

POUFFY TUKAN

KG: 84,0 m³: 1,96 **KG: 42,0 m³: 0,98** **KG: 42,0 m³: 0,98**



FOX
PAISLEY

FELIX
PAISLEY

AWESOME AND TOTALLY PERFECT

**FOX
PAISLEY**



Using nature-themed decor can make your room very calming and provide an ideal environment for relaxation. Decorating in a rain-forest theme allows you to unleash your creativity and make use of outdoor decor in ways that you've never imagined. Incorporate many rain-forest themed decorations into your home for little expense.

**OPERA
VIRGINIA**





BRISTOL
BOHO

CHELSEA
BOHO POUF



NATURA
BOHO



BRISTOL
BOHO



NATURA
BOHO



METROPOL
BOHO

Timeless and
striking
concept of
style



NICE
BOHO

Technical Details

<p>BRISTOL BOHO BEDSTEAD 180</p> <p>KG: 95,0 m³: 0,92</p>	<p>BRISTOL BOHO BEDSTEAD 160</p> <p>KG: 89,8 m³: 0,83</p>	<p>BRISTOL BOHO NIGHTSTAND</p> <p>KG: 43,70 m³: 0,24</p>					
<p>OPERA 3 SOFA</p> <p>KG: 76,0 m³: 1,72</p>	<p>METROPOL RELAX LEFT TRIPLE</p> <p>KG: 141,0 m³: 2,92 KG: 65,0 m³: 1,47 KG: 76,0 m³: 1,45</p>						
<p>FOX PAISLEY</p> <table border="0"> <tr> <td data-bbox="1721 1116 2107 1487"> <p>ARM MODULE LEFT</p> <p>KG: 35,7 m³: 0,61</p> </td> <td data-bbox="2138 1116 2523 1487"> <p>INTER MODULE</p> <p>KG: 30,0 m³: 0,51</p> </td> <td data-bbox="2554 1116 2937 1487"> <p>ARM MODULE RIGHT</p> <p>KG: 35,7 m³: 0,61</p> </td> <td data-bbox="2554 1116 2937 1487"> <p>POUF</p> <p>KG: 20,0 m³: 0,22</p> </td> </tr> </table>				<p>ARM MODULE LEFT</p> <p>KG: 35,7 m³: 0,61</p>	<p>INTER MODULE</p> <p>KG: 30,0 m³: 0,51</p>	<p>ARM MODULE RIGHT</p> <p>KG: 35,7 m³: 0,61</p>	<p>POUF</p> <p>KG: 20,0 m³: 0,22</p>
<p>ARM MODULE LEFT</p> <p>KG: 35,7 m³: 0,61</p>	<p>INTER MODULE</p> <p>KG: 30,0 m³: 0,51</p>	<p>ARM MODULE RIGHT</p> <p>KG: 35,7 m³: 0,61</p>	<p>POUF</p> <p>KG: 20,0 m³: 0,22</p>				
<p>TV TOP MODULE (GLASS) TV TOP MODULE (SHELF)</p> <p>TV SUB MODULE</p> <p>TV SUB MODULE (WITH DRAWER)</p> <p>KG: 142 m³: 1,03</p>		<p>CONSOLE</p> <p>MIRROR</p> <p>KG: 124,8 m³: 0,36</p>	<p>TABLE</p> <p>KG: 62,5 m³: 0,29</p>				



EGE, WILD

MAGNUM, WILD

CAPELLA
POUF



wild
MAGNUM



EDGE
wild

**EYE-CATCHING
DETAILS**

A DIFFERENT, STYLISH AND
FASHIONABLE MASTERPIECE





EGE, WILD

MILAN, WILD

CAPELLA
POUF

MAGNUM, WILD



EXPLORE THE LOOK

EMPHASIZING THE DURABILITY OF THE
SKELETON SYSTEM, VILLA OFFERS YOU
A COMFORTABLE LIFE WITH ITS
MODERN DESIGN APPROACH.

VILLA *Insidat*





Technical Details

VILLA WILD
BEDSTEAD 180

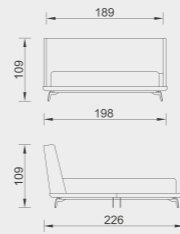

KG: 140,8 m³: 1,16

VILLA WILD
BEDSTEAD 160

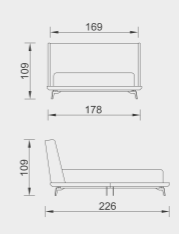

KG: 105,5 m³: 0,90

EGE ARMCHAIR

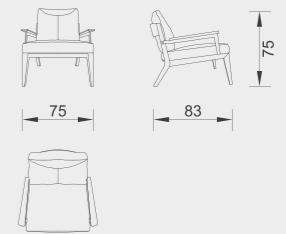

KG: 21 m³: 0,41

MILAN



KG: 112,3 m³: 2,01

90CM ARM MODULE LEFT

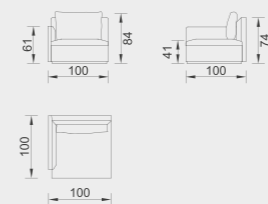

KG: 44,6 m³: 0,77

90CM INTER MODULE

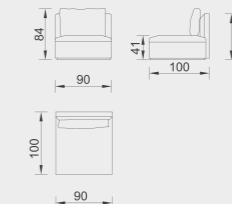

KG: 37,7 m³: 0,73

130CM POUF

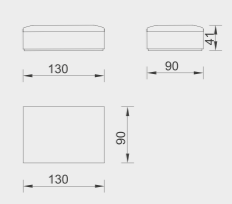

KG: 30 m³: 0,51

MAGNUM SOFA

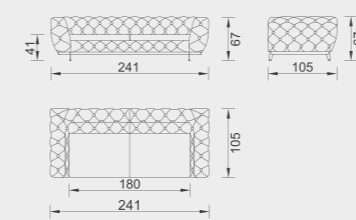

KG: 94,2 m³: 1,50

CAPELLA POUF

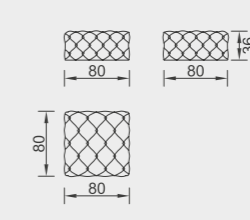

KG: 13,2 m³: 0,28



PICASSO
NATIVE

CALIFORNIA,
PINK POUF

CHELSEA
GIPSY POUF

POUFY, GIPSY

PISSA

The first step in creating a room that relaxes you is to know your style. Then you can use it to personalize your interior with the tools and suggestions below. Hope today's post is a relaxing read!



PICASSO
NATIVE



PICASSO
SUN



PICASSO
POPPY



AMOUR
DIVERSE

AMOUR
CORAL

CHELSEA
GIPSY POUF

CALIFORNIA
POUF

GIPSY AMOUR



AMOUR
DIVARSE



AMOUR
CORAL

Many people associate feathers with femininity and an innocent sort of beauty. Some even relate feathers as symbolic of having a lighter outlook on life and positivity, so it's fitting that feathers are a huge trend for interior décor and style. A delicate and tactile trend feathers can be used in all elements of your home decor.



MOI
LEMON
ARMCHAIR



CALIFORNIA
POUFF



AMOUR
LEMON



Explore the look.



**SMART ROXY
ARMCHAIR**

There are a wide variety of styles in the decoration. This creates a wide selection and many opportunities. The most important thing is that you correctly select the decoration according to the mood of the event. One of the most important components of decoration flowers are without a doubt.

Technical Details

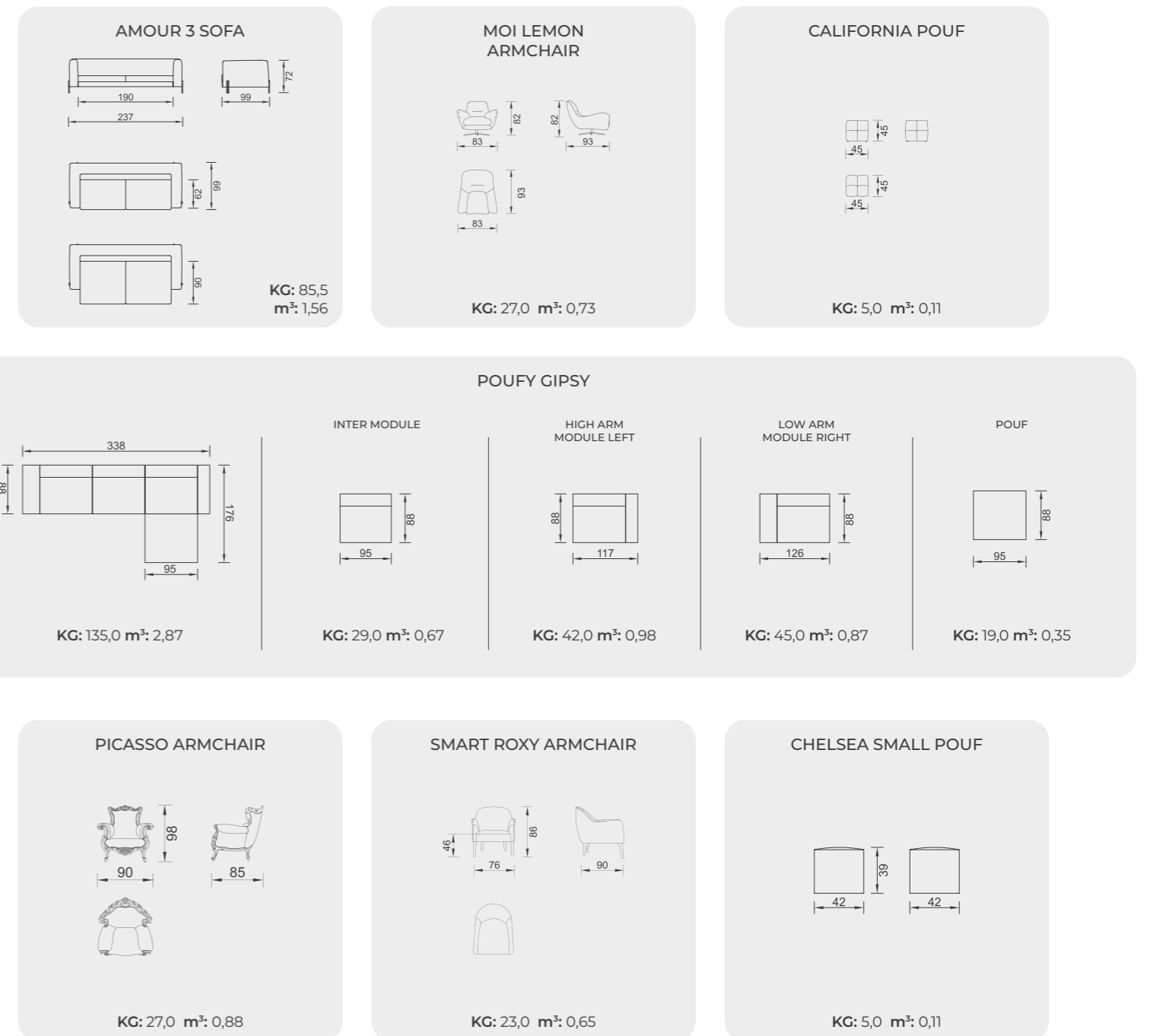



COMPLEMENT

It is possible to create miracles in decoration with Bristol.

PAGE - 94



BRISTOL
DALI

NON FIGURATIVE, SALONI



BRISTOL
DALI



MILAN
MONDRIAN

EGE
MONDRIAN

MILAN
MONDRIAN



PAGE - 99
MILAN



A design that provides high comfort in sitting areas with the sponge structure used.

A CONTEMPORARY ATMOSPHERE!





ELEGANT AND REFINED
 An impressive style that provides unity in design with color and texture transitions.

Technical Details

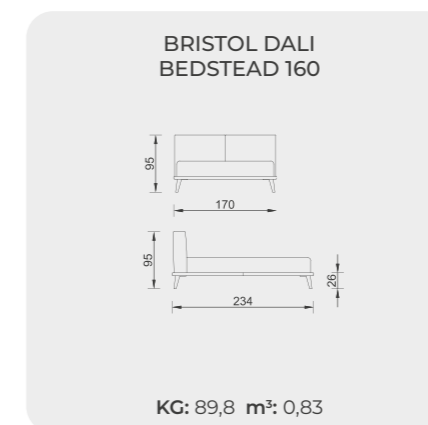
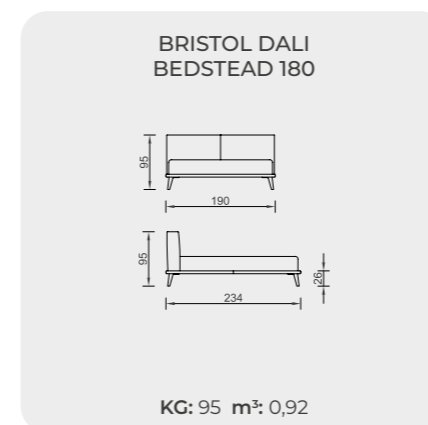
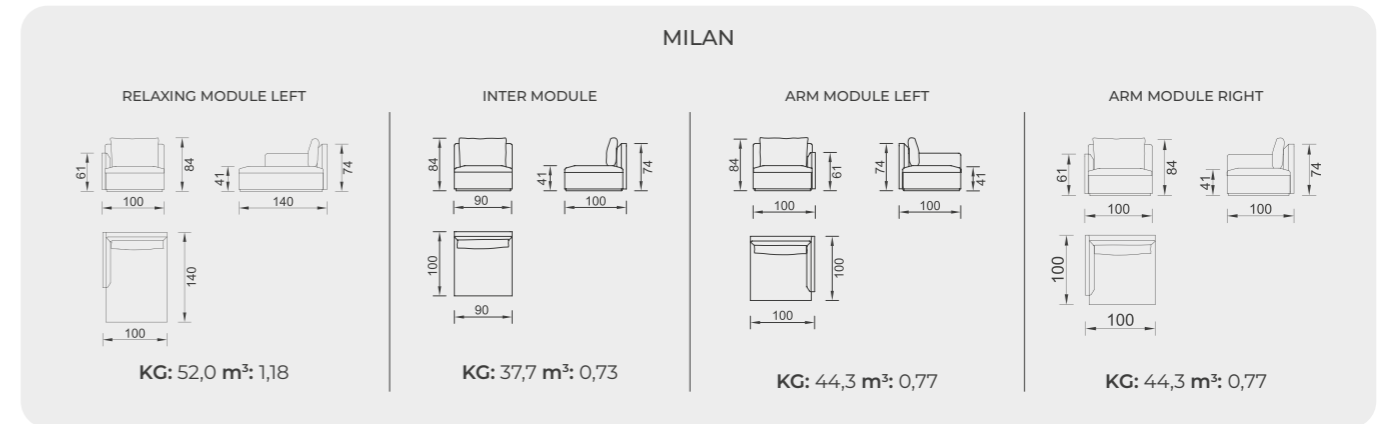



PICASSO
XANAX

FOX
XANAX



for the treatment of stress and fatigue during the day, it is strongly recommended.

XANAX

HAVE YOU

EVER WALKED INTO



A ROOM AND INSTANTLY FELT CHILL?

What makes a space relaxing? Soothing? Calm? Have you ever walked into a room and instantly felt chill? Today we explore interior design solutions for creating a relaxing interior. The good news: you don't have to break the bank to achieve a restful space. While there are no tried and true rules for making your interior a calm one, there are certain features that many of today's most peaceful homes share. The solution is fox Xanax.

The Power of Patterns

A style that combines different patterns and carving art.

EFES EMMA



EFES PHONE



EFES ISABELLA



EFES MEDISON

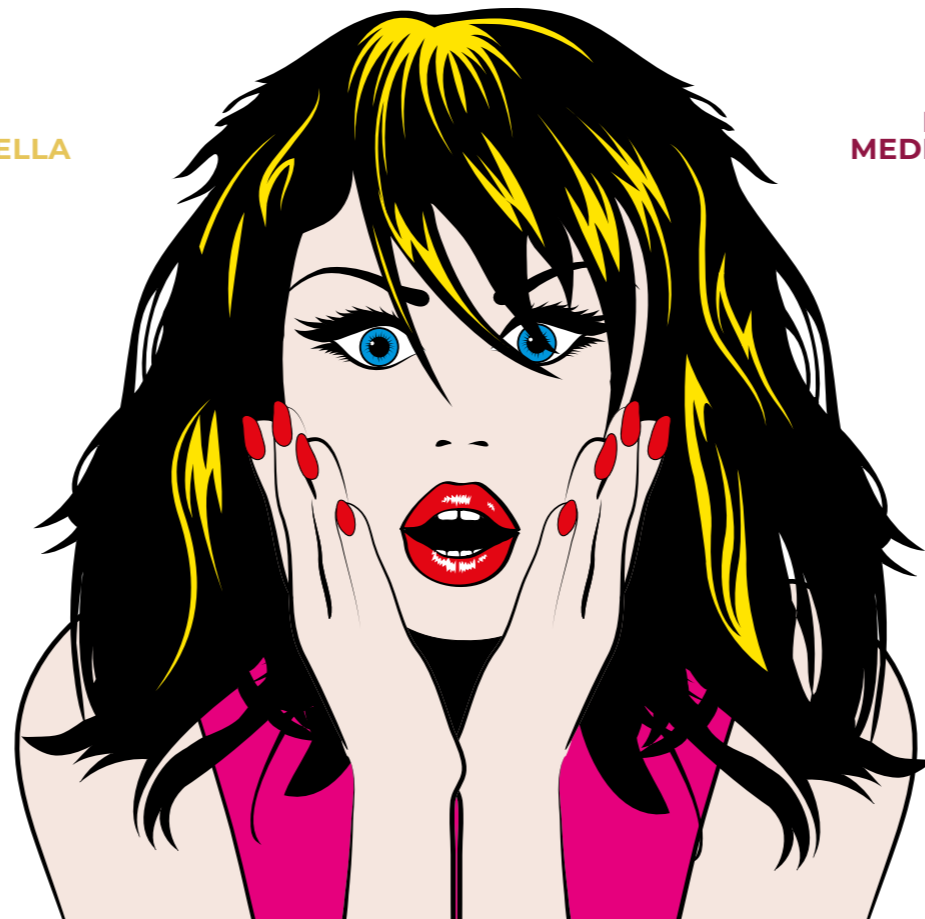



P A C E - 108

COLORIUM, SALONI

ASPENDOS
ELENOR



Sweet Dreams Are Made of This

**ASPENDOS
HAPPY**

**PICASSO
HAPPY**



PICASSO
HAPPY



ASPENDOS *happy*



ASPENDOS
HAPPY

Modern research has shown that when our eyes connect with a color, our brains release different chemicals that impact us on a physical and emotional level. For instance, being in a red room will increase your heart rate and stimulate chemicals associated with aggression and high energy, while the color yellow stimulates serotonin (the feel-good chemical) in our brains.

Color therapy has been practiced in traditional healing professions for many years, but marketers and businesses more recently have also used color to shift human moods. Once we learn a bit about the attributes of each color, we can use that information to promote the atmosphere we want in the different rooms of our homes. Here are some ideas.

ARM MODULE LEFT

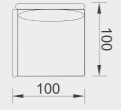

KG: 35,7 m³: 0,61

ARM MODULE RIGHT

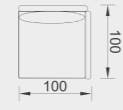

KG: 35,7 m³: 0,61

INTER MODULE



KG: 30,0 m³: 0,51

CORNER MODULE RIGHT

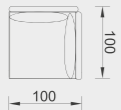

KG: 36,0 m³: 0,63

CORNER MODULE LEFT

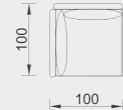

KG: 36,0 m³: 0,63

POUF

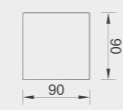

KG: 20,0 m³: 0,22

OPTION 1

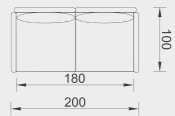

KG: 71,4 m³: 1,22

OPTION 2

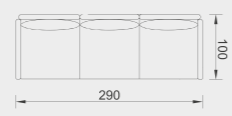

KG: 101,4 m³: 1,73

OPTION 3

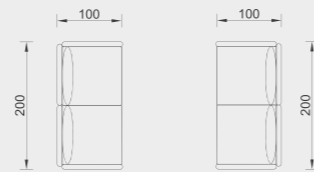

KG: 142,8 m³: 2,44

OPTION 4

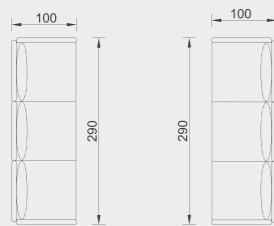

KG: 202,8 m³: 3,46

OPTION 5

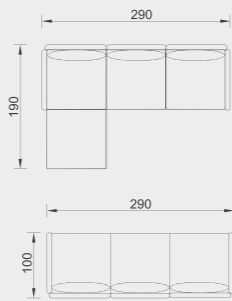

KG: 222,8 m³: 3,68

OPTION 6



KG: 121,4 m³: 1,95

OPTION 7



KG: 86,0 m³: 1,36

OPTION 8

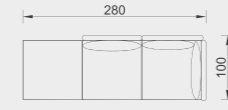

KG: 86,0 m³: 1,36

OPTION 9

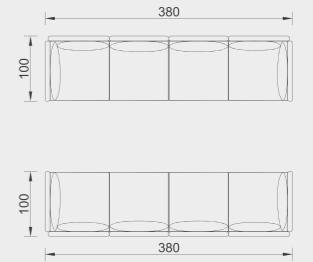

KG: 264,0 m³: 4,56

OPTION 10

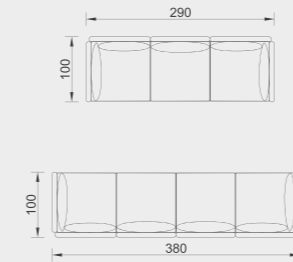

KG: 234,0 m³: 4,05

OPTION 11

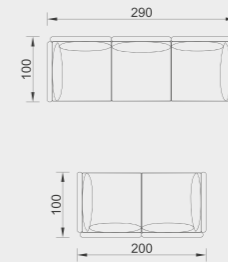

KG: 174,0 m³: 3,03

OPTION 12

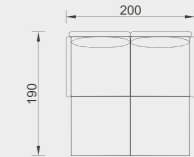

KG: 111,4 m³: 1,66

OPTION 13

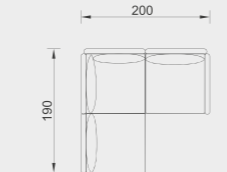

KG: 101,7 m³: 1,75

OPTION 14

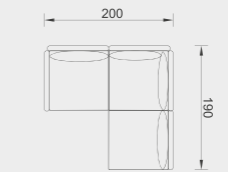

KG: 101,7 m³: 1,75

OPTION 15

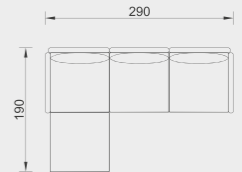

KG: 121,4 m³: 1,95

OPTION 16

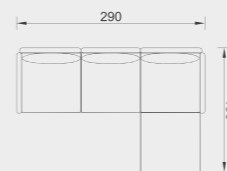

KG: 121,4 m³: 1,95

OPTION 17

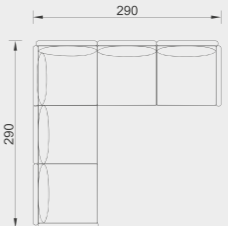

KG: 167,4 m³: 2,87

OPTION 18

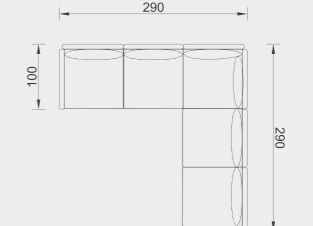

KG: 167,4 m³: 2,87



Technical Details

Technical Details

OPTION 19

KG: 197,4 m³: 3,38

OPTION 20

KG: 227,4 m³: 3,89

OPTION 21

KG: 227,4 m³: 3,89

OPTION 31

KG: 192,0 m³: 3,30

OPTION 32

KG: 162,0 m³: 2,79

OPTION 33

KG: 120,0 m³: 2,04

OPTION 22

KG: 293,4 m³: 5,03

OPTION 23

KG: 201,7 m³: 3,21

OPTION 24

KG: 211,7 m³: 3,50

OPTION 34

KG: 152,0 m³: 2,50

OPTION 25

KG: 151,4 m³: 2,46

OPTION 26

KG: 137,4 m³: 2,36

OPTION 27

KG: 137,4 m³: 2,36

ASPENDOS

KG: 75 m³: 1,86

PICASSO ARMCHAIR

KG: 27 m³: 0,88

EFES ARMCHAIR

KG: 13 m³: 0,59

OPTION 28

KG: 217,4 m³: 3,50

OPTION 29

KG: 217,4 m³: 3,50

OPTION 30

KG: 263,4 m³: 4,52



saloni
art of furniture
2021-1
saloni.com.tr